

**SCHMITT**  
Kreiselpumpen

**chemical resistant pumps  
for corrosive and highly pure media**

# **Operating Maintenance Assembly Instruction**

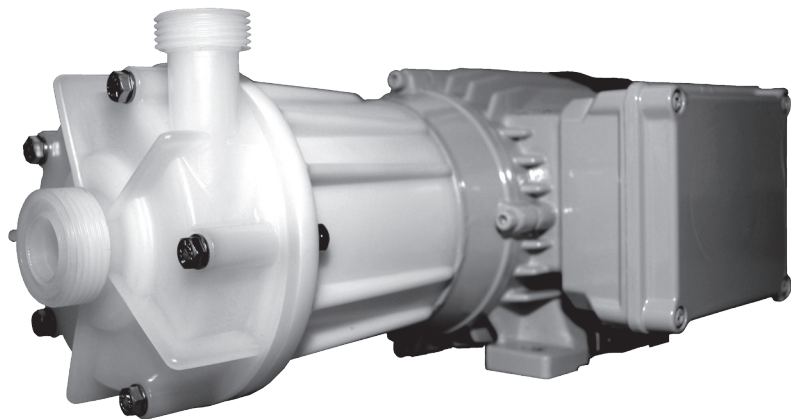

## **MPN Pump Series**

**normal priming,  
magnetically coupled  
centrifugal pumps**

**materials: PVDF or PP**

## General instructions

The present operating instructions must be complied with when installing, operating and servicing the pumps. This is the reason why these instructions must be read by the operator, the assembling personnel and all the other specialists/operators before installing and commissioning the pump. These instructions must be readily available for consultation at the site of installation.

The personnel in charge of operation, maintenance, inspection and assembly must be qualified to carry out this work. The scope of the personnel's responsibility, competence and supervision must be precisely defined by the management. The management must also ensure that the operating instructions are fully understood and complied with by the personnel.

Non-compliance with the present instructions may not only cause damage to the environment and be dangerous for the personnel but may also result in the total destruction of or damage to the pump or the installation.

The present instructions, current national measures for accident prevention, and all internal works-, operating- and safety instructions specified by the user are to be complied with.

The work is to be carried out on inactive pumps. Pumps which are used with hazardous materials must be decontaminated. Before started such pumps up again, the instructions for initial commissioning are to be complied with.

## Installing the pump

The pump is to be installed horizontally at the chosen operating site. Monobloc pumps are installed stress-free in situ (on the ground or the bottom plate) with the help of the feet.

## Relocating pipelines

Prior to installing a **SCHMITT centrifugal pump**, please ensure the very best and appropriate arrangement of the connecting tubes. Inappropriate tube cross section and erroneous arrangement can result in lost performance, and even damage.

The pipeline's nominal width and the incorporated armature must be of equal width or wider than the pump's nominal width. Suction lines must be as short as possible. Sharp bends must be avoided, especially before the pump's suction connection pieces. Pipelines are to be connected to the pump in such a manner that no forces act on the pump (e.g. mismatch, weight or dilation when hot liquids are being pumped). Use compensators or flexible connection pieces. This also applies in the event of metal pipelines.

## Operation

Avoid pumping solids and mud. If necessary, overflow protection, filters or screen cages are to be incorporated into the suction line. Please be careful that these do not become blocked since the pump will otherwise cavitate. This can result in damage, particularly to the plain bearings.

**Warning: people with pace-makers may not install, service or operate pumps.**

Pump Series: MPN 80 - MPN 190  
Materials: PVDF or PP

These pumps are “normal priming”, i.e. the feeding medium has to feed into the pump.

The axial input is located centrally in the housing, with the output leading tangentially right to the top (standard version).

The pumps do not have an axial face seal and are, therefore, equipped with low-maintenance hydro-dynamic bearings. These are made of various different materials, depending on their use. Dry-running of the pumps generates heat which can result in damage to the bearings and other parts of the pump.

**Never allow the pump to run dry - this also applies to rotational direction tests of the motor!**

Once the pumps have been installed at the chosen site, and the suction and pressure lines have been properly connected, the pump is filled with liquid. Please make sure that the lines and the pump have been bled. Also ensure that all the connected lines are absolutely watertight.

Before connecting the motor to the power supply, please match the voltage with the indications on the motor.; check explosion-proof motors for their protection class.

The connection must comply with VDE regulations and those of the local electricity board.

Test the pump's rotational direction by giving it a brief current pulse. Switch the pump on by activating the closed slide valve on its pressure side. Subsequently, open the slide valve to reach the desired flowing or working point.

Only operate the pumps very briefly with closed, pressure-side slide valve. The axial face seal and other parts may be damaged due to overheating of the pumping medium.

**Suction-side throttling is not permitted.** This results in cavitation; performance levels fall off and damage may be caused to pump parts and axial face seals.

Only use the pumps for the pumping mediums and operating conditions specified in the order form. As stated in our General Terms of Sale, we shall not be held liable, for any damage which resulted from non-compliance with the present operating instructions.

Pump Series: MPN 80 - MPN 190  
Materials: PVDF or PP

Before dismantling the pumps, secure them so as to ensure that they cannot be switched on. The pump housing must have reached ambient temperature, must be unpressurized and empty. Carefully clean the pump when this is used for hazardous and environmentally dangerous feeding media. Pollutants from this operation are to be disposed of in the appropriate manner.

## Dismantling

Once the housing screws (27-3) have been released, remove the housing (06), and pull out the impeller (04) and the cover (05).

Should the support (07) have to be removed, first release the bolt (09). An opening has been provided under the flange (01) to facilitate this operation. This opening also serves when stripping the cylinder from the motor shaft. The cylinder's external magnets are only damaged when the pump is operated for quite some time with a block rotor disk. Eddy current formation produces a rise in temperature of the external magnets and a loss in transmission torque.

## Replacing worn parts

The rings (13v) and (10h) have been sunk into the housing (06) and the cover (05) by heating and must, if necessary, only be replaced in the our factory.

Unscrew the rotating-bearing (12v, right-hand thread) mounted on the impeller and the rotating-bearing (11h, left-hand thread) and tighten the new parts only by hand. Through holes and relief holes must be checked for blockages and are if necessary to be cleaned.

## Assembling the external magnet support

Push the support out of the motor shaft until measurement "C" for the appropriate type of pump is reached (see drawing). Tighten the bolt (09).

## Assembling the pump parts

Place the cover (05) on the flange (01) and insert the housing seal (36) into the groove provided for this purpose.

**Warning: when inserting the impeller through the cover, powerful axial magnetic forces occur.**

Insert the impeller very gradually in the cover using both hands, since the rotating bearing (11h) may otherwise be damaged. Put the housing back into position and tighten with the housing screws.

Check for smooth and even running by rotating the motor fan blade.

### **Attention!**

**When ordering spare parts, please mention the pump's reference number.**

When starting the pump up again, please comply with the instructions for **commissioning**.

# Parts Description of the MPN Pump Series

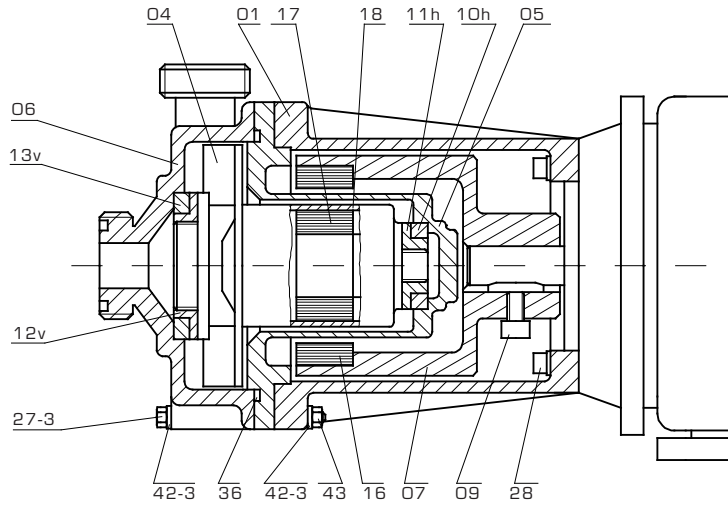

part-no.	part	material	
		standard	on request
01	mounting flange	PP* /AL	
04/17	impeller with magnet + cover	PVDF	PP
18	mouthring (left-hand thread)	PVDF	PP
11h	mouthring (right-hand thread)	PTFE	SiC
12v	mouthring (right-hand thread)	PTFE	SiC
05	backplate + stationary ring	PVDF	PP
10h	stationary ring	Ceramic	SiC
06	pump housing + stationary ring	PVDF	PP
13v	stationary ring	Ceramic	SiC
36	pump housing seal	FKM**	FEP or EPDM
07	support with magnet + cylinder bolt		
16/09			
27-3	hexagon bolt	A4	
28	cylinder bolt	A4	
42-3	washer	A4	
43	hexagon bolt	A4	

\*MPN 101-150: PP, others: AL

\*\*FKM = e.g. Viton®

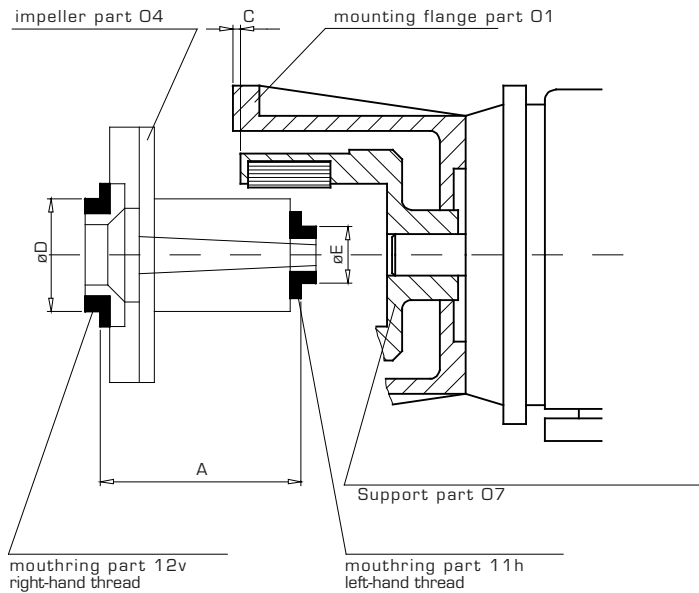

type	A	C	axial play	D	E
MPN 80	56,5	5,0	1,0	33,8	19,8
MPN 101	64,0	6,5	1,0	41,8	19,8
MPN 115	66,0	5,5	0,8	41,8	19,8
MPN 130	80,0	6,0	0,8	41,8	19,8
MPN 150	82,5	6,5	1,2	64,7	33,8
MPN 170	108,5	7,5	2,0	64,7	33,8
MPN 190	109,0	7,0	2,0	64,7	33,8

# Characteristics of the MPN Pump Series

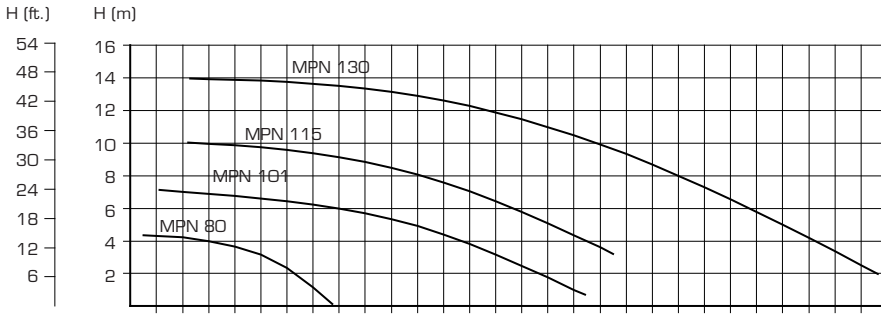

MPN 80 - MPN 130 Pump Series

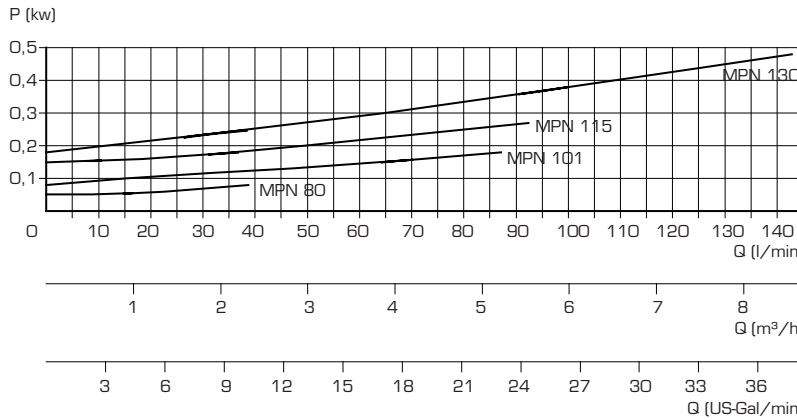

Motor power

MPN 130	0,55 kw
MPN 115	0,25 kw
MPN 101	0,18 kw
MPN 80	0,18 kw

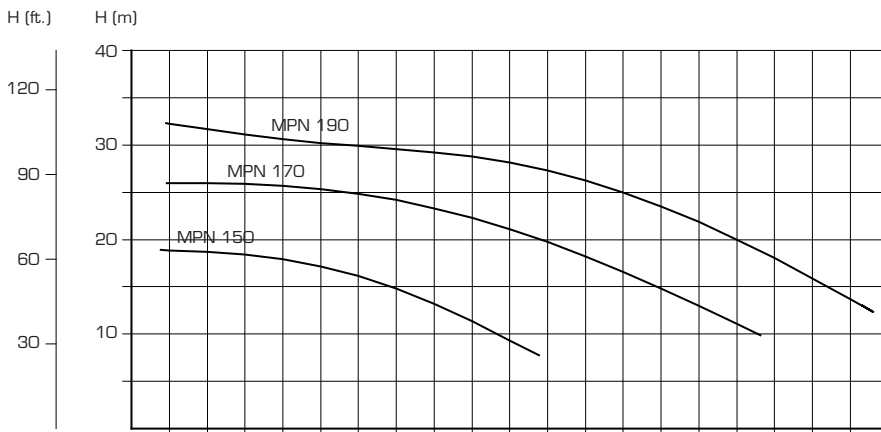

MPN 150 - MPN 190 Pump Series

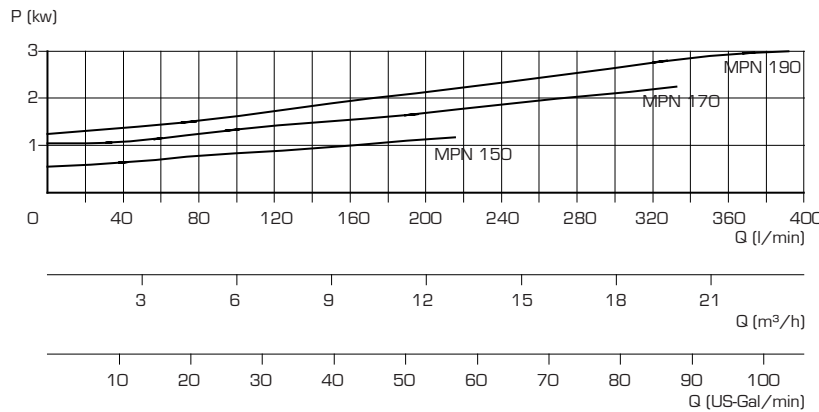

Motor power

MPN 190	3,00 kw
MPN 170	2,20 kw
MPN 150	1,10 kw

Characteristic lines measured with water, 20° C and 2900 Rpm (50 Hz.)

# Specification of the MPN Pump Series

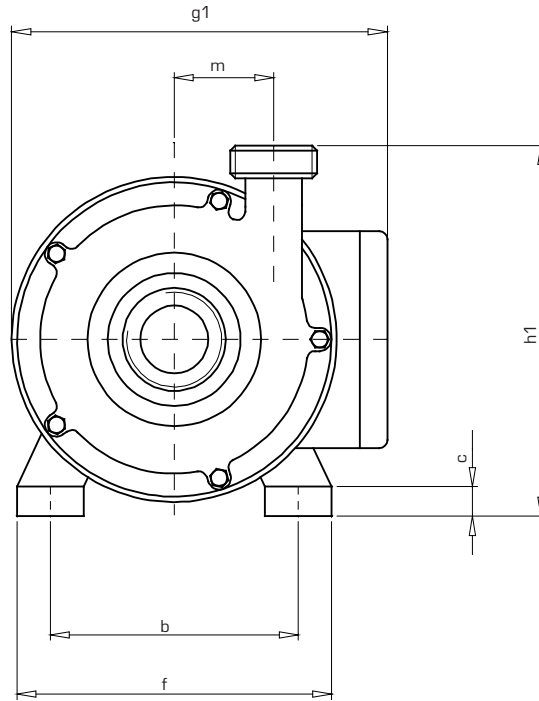

type	h	h1	l	l1	l2	g	g1	p	a	b	e	f	c	ø s	m	suction conn.		pressure conn.		weights kg
																nom. bore	male thread	nom. bore	male thread	
MPN 80	56	110	290	123	158	111	164	113	71	90	90	112	8	6	25	10	G 3/4"	10	G 3/4"	4,6
MPN 101	56	118	297	131	165	111	164	113	71	90	90	112	8	6	31	15	G 1"	15	G 1"	4,5
MPN 115	63	134	335	145	185	126	156	126	80	100	97	116	6	7	37	15	G 1"	15	G 1"	5,3
MPN 130	71	150	372	153	203	139	194	140	90	112	108	140	10	8	42	20	G1 1/4"	15	G 1"	8,6
MPN 150	80	170	415	178	228	157	209	159	100	125	125	160	11	10	47	25	G1 1/2"	20	G1 1/4"	15,3
MPN 170	90	190	495	222	277	177	235	180	125	140	152	180	14	11	58	32	G 2"	25	G1 1/2"	23,8
MPN 190	100	211	535	235	295	198	255	200	140	160	175	205	14	12	65	32	G 2"	25	G1 1/2"	30,0

The dimensions of the motors refer to three-phase standard motors.

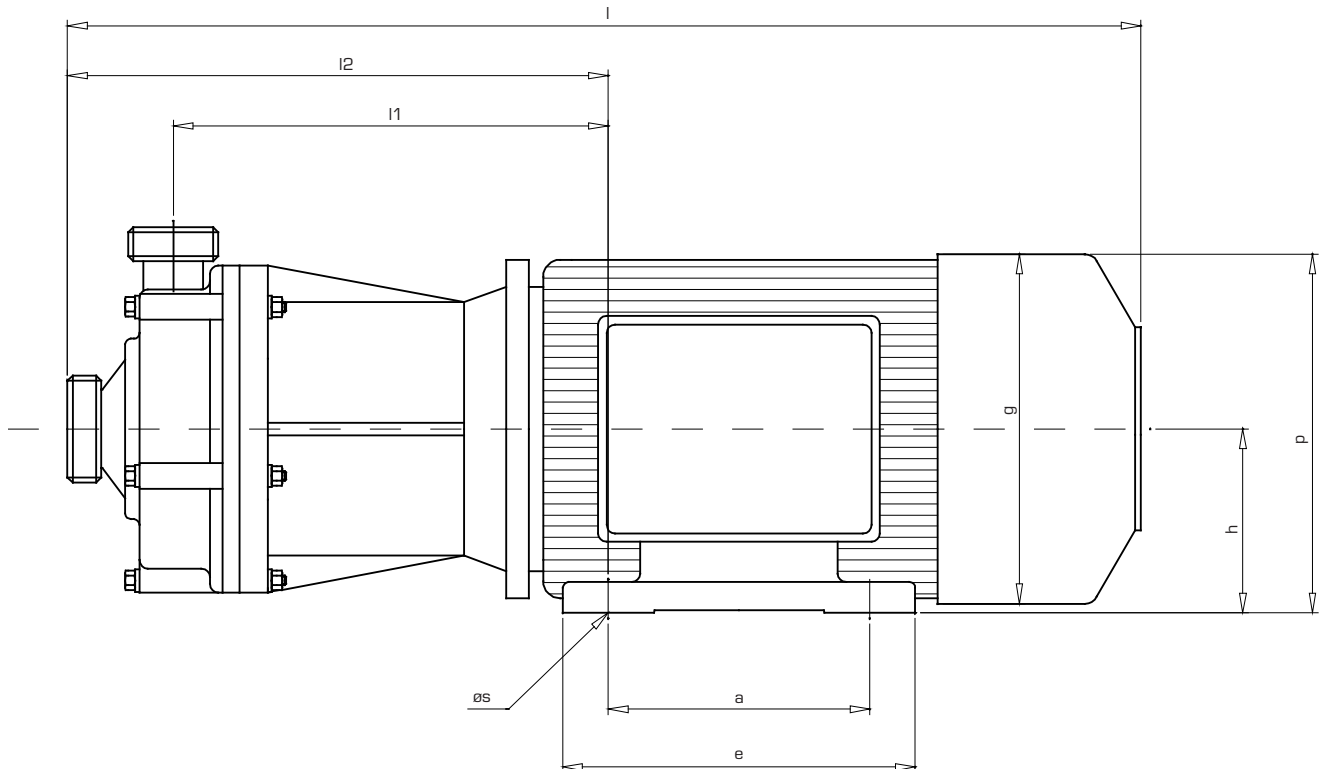

## General conditions

**SCHMITT centrifugal pumps** meet very high design and engineering specifications.

Appropriate assembly and operation, as recommended in the present operating instructions, are a prerequisite for troublefree continuous operation.

Thus, in order necessary to comply with the present instructions for assembly and commissioning of the pumps, as well as for maintenance work, it is necessary to read these carefully and to comply with the recommendations. Each and every **SCHMITT centrifugal pump** has been given a reference number which is to be mentioned in all subsequent correspondence and when ordering spare parts.

## Warranty

We provide a guarantee in accordance with our General Terms of Sale.

Please advise us immediately of any damage which may have occurred during the guarantee period. Only prompt action will give you a right to claim on the guarantee.

We shall only be liable for all those materials and versions recommended by us, to the extent that the operating instructions and the feeding liquids match the specifications requested at the time of ordering the equipment.

Please contact us should any alterations have to be made concerning the concentrations and the temperature of the feeding medium or the hydraulic data. We shall then check to see whether the pump supplied by us can be used in such operating conditions. As mentioned in our General Terms of Delivery, we shall not be liable for any damage resulting from non-compliance with the operating instructions.

Please inform us writing prior to any modifications or maintenance work carried out during the period of guarantee. Omission to do so will cancel the present guarantee. Such modifications or maintenance work are only to be carried out by specialised personnel or else you may send us the pump for an expert opinion or repairs.

We shall not to be held liable for any pump parts which show signs of premature wear and tear due to their material properties or the way in which they were used, such as axial face seals, seals and similar.

We only guarantee spare parts not made by us within the limits of the guarantee awarded to us by the sub-contractor.